

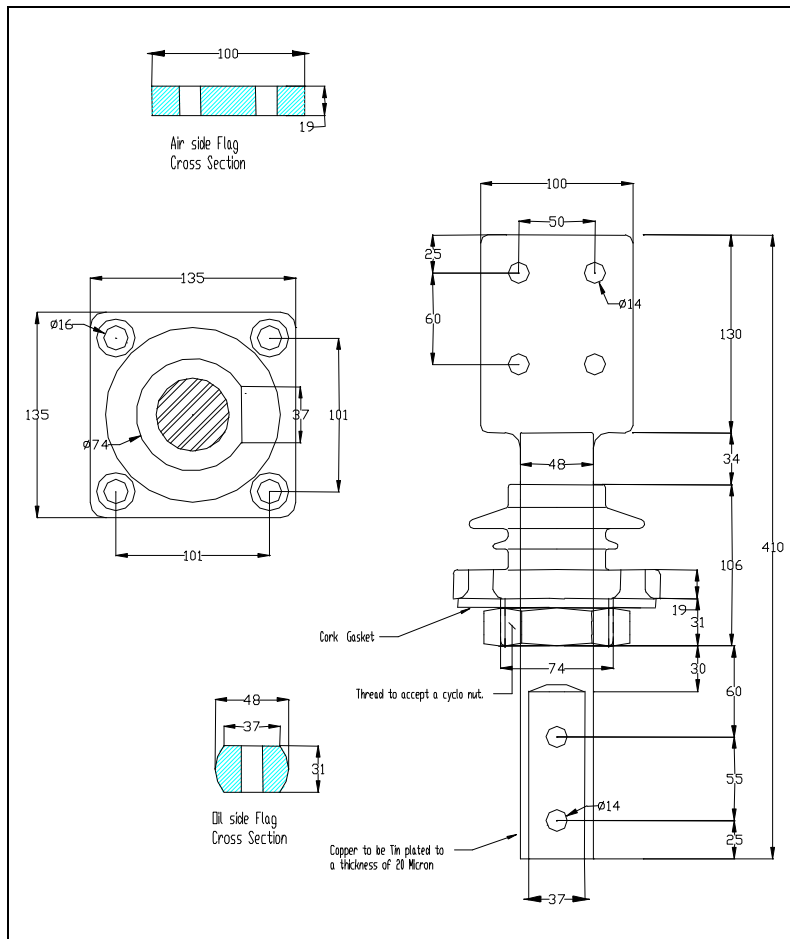

## TRANSFORMER BUSHING 2TB SERIES

Up to 3.6kV – 3150A



### Application

For use in equipment insulated with oil fluid, typically transformers.

### Design

Moulded PH-CEP\* hydrophobic cycloaliphatic epoxy insulated part with a choice of current ratings. Features either locknut or bolted mounting. One piece swaged tinned copper conductor.

### Standards

EMCP bushings meet the characteristics of AS1265, 1990 and relevant IEC standards.

### Quality

Each bushing is put through stringent quality assurance in line with the EMC Pacific ISO9001 Quality Management System.

Manufactured in Australia by EMC Pacific Pty Ltd, Dandenong, Victoria.

Specification and product design are subject to change without notice. All Information is accurate at time of printing.

### Specification

\*Permanent Hydrophobic Cycloaliphatic Epoxy Resin (patent applied)

Product No	2TB – 3150
Highest Voltage for Equipment (kV)	3.6 kV
Line Voltage (kV)	3.3 kV
Max Current Rating (A)	3150 A
Impulse Withstand Voltage (kV)	50 kV
Dry Power Frequency Withstand Voltage (kV)	16 kV
Wet Power Frequency Withstand Voltage (kV)	16 kV
Creepage	150 mm
Weight	7 kg