

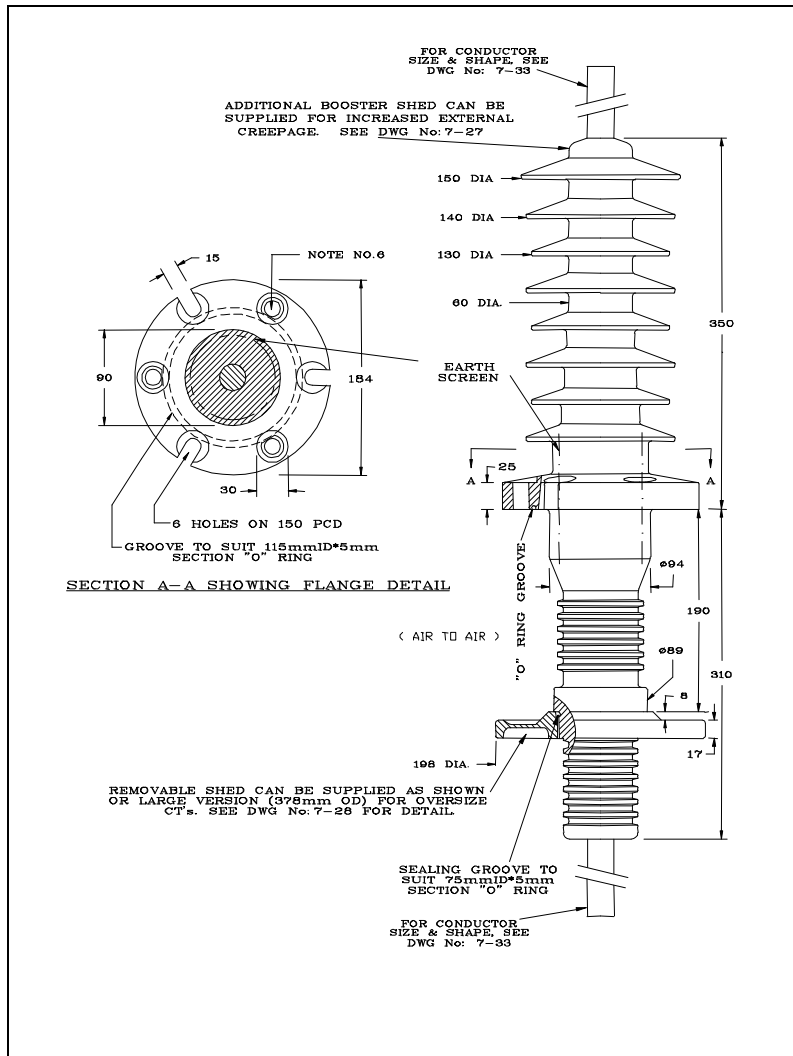

FLANGED THROUGH BUSHING

FTB 26 SERIES

Up to 36kV – 1600A



Application

For use as an outdoor to indoor air insulated through bushings. Suit cable box installations, transformers and outdoor circuit breakers.

Design

Moulded epoxy insulated with a choice of current ratings. Features either locknut or bolted mounting.

Standards

EMCP bushings meet the characteristics of AS1265, 1990 and relevant IEC standards.

Quality

Each bushing is put through stringent quality assurance in line with the EMC Pacific ISO9001 Quality Management System.

Ordering instructions

Bushings are supplied with a choice of current ratings; 800A, 1600A. These are to be specified at order time.

Manufactured for EMC Pacific Pty Ltd by Electrical Moulded Components (Pty) Ltd. Import lead times may apply

Specification and product design are subject to change without notice. All Information is accurate at time of printing.

Specification

Product No	FTB 26/25	FTB26/38
Highest Voltage for Equipment (kV)	36 kV	36 kV
Line Voltage (kV)	33 kV	33 kV
Max Current Rating (A)	800 A	1600 A
Impulse Withstand Voltage (kV)	200 kV	200 kV
Dry Power Frequency Withstand Voltage (kV)	70 kV	70 kV
Dry Arc Distance (mm)	385 mm	385 mm
Creepage (mm)	830 mm	830 mm
Conductor size (Ømm)	25 mm	38 mm
Weight	12 kg	14 kg