

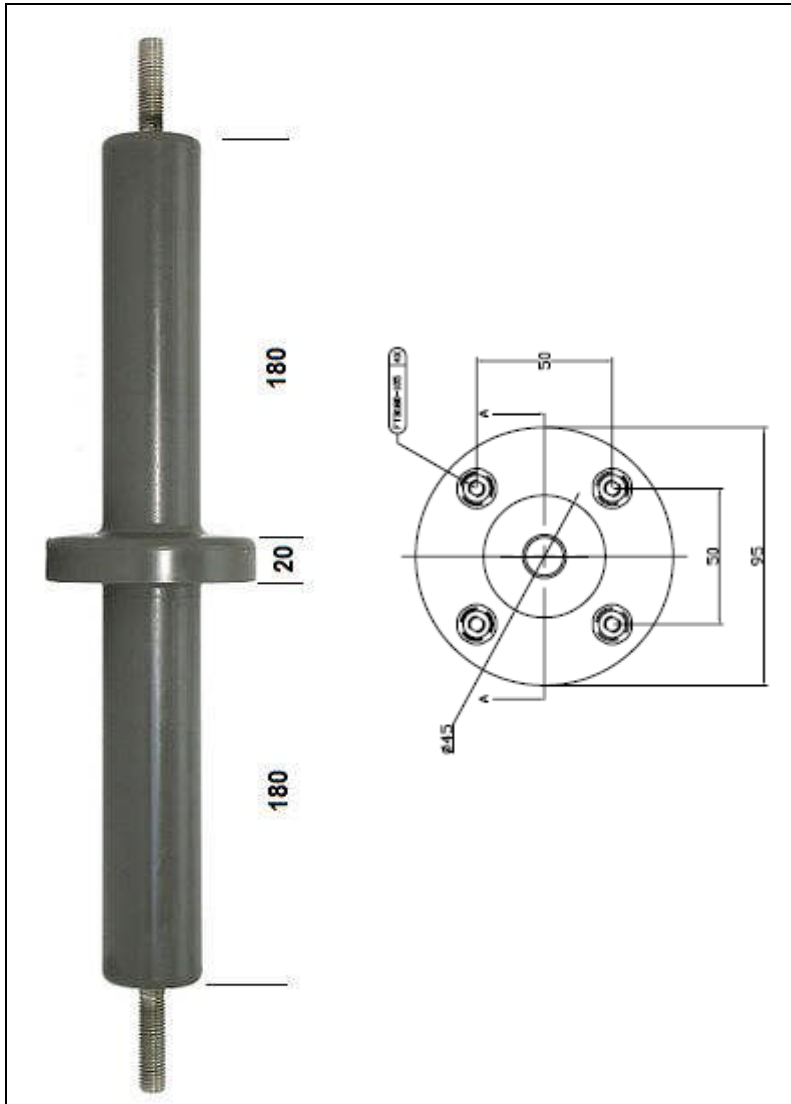

FLANGED THROUGH BUSHING

FTB 180 SERIES

Up to 12kV – 800A



Application

For use as an indoor air insulated through bushings. Suit panel to panel switchgear installations or dry type transformers.

Design

Moulded PH-CEP* hydrophobic cycloaliphatic epoxy insulated part with insert mounting.

Standards

EMCP bushings meet the characteristics of AS1265, 1990 and relevant IEC standards.

Quality

Each bushing is put through stringent quality assurance in line with the EMC Pacific ISO9001 Quality Management System.

Ordering instructions

Bushings are supplied with a choice of current ratings; 250A, 400A, 600A, 800A. Please specify current rating requirement at time of order.

Manufactured in Australia by EMC Pacific Pty Ltd, Dandenong, Victoria.

Specification and product design are subject to change without notice. All Information is accurate at time of printing.

Specification

*Permanent Hydrophobic Cycloaliphatic Epoxy Resin (patent applied)

Product No	FTB 180 -12	FTB 180 -16	FTB 180 - 20	FTB 180 – 25
Highest Voltage for Equipment (kV)	12 kV	12 kV	12 kV	12 kV
Line Voltage (kV)	11 kV	11 kV	11 kV	11 kV
Max Current Rating (A)	250 A	400 A	600 A	800 A
Impulse Withstand Voltage (kV)	95 kV	95 kV	95 kV	95 kV
Dry Power Frequency Withstand Voltage (kV)	28 kV	28 kV	28 kV	28 kV
Creepage (mm)	191 mm	191 mm	191 mm	191 mm
Conductor size (Ømm)	12 mm	16 mm	20 mm	25 mm